

MILEPOST project

GCC ICI

Static multi-versioning for
dynamic optimizations

Grigori Fursin

INRIA Saclay, France

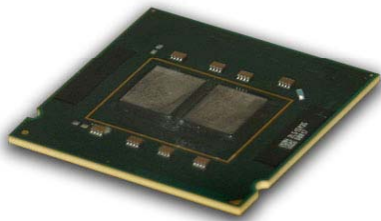

MILEPOST project

Machine Learning for Embedded Programs Optimization

Objective is to develop compiler technology that can automatically learn how to best optimize programs for re-configurable heterogeneous embedded processors (with run-time adaptation) and dramatically reduce the time to market.

Partners:

University of Edinburgh, INRIA, IBM, ARC, CAPS Enterprise

Developed techniques and software are publicly available and hopefully will influence the future compiler developments



MILEPOST

<http://www.milepost.eu>

MILEPOST framework

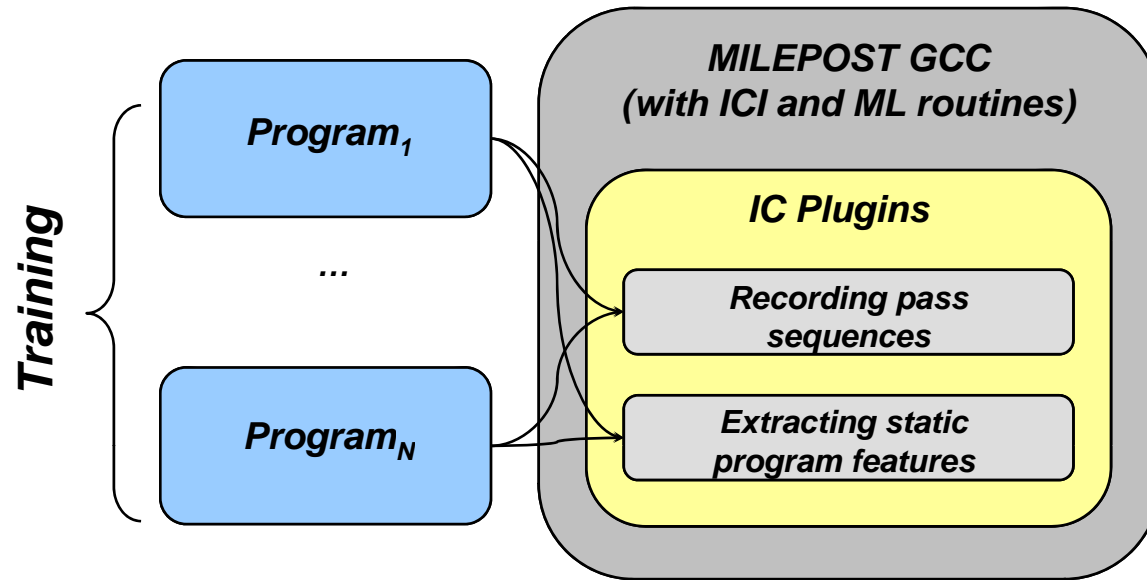

MILEPOST framework

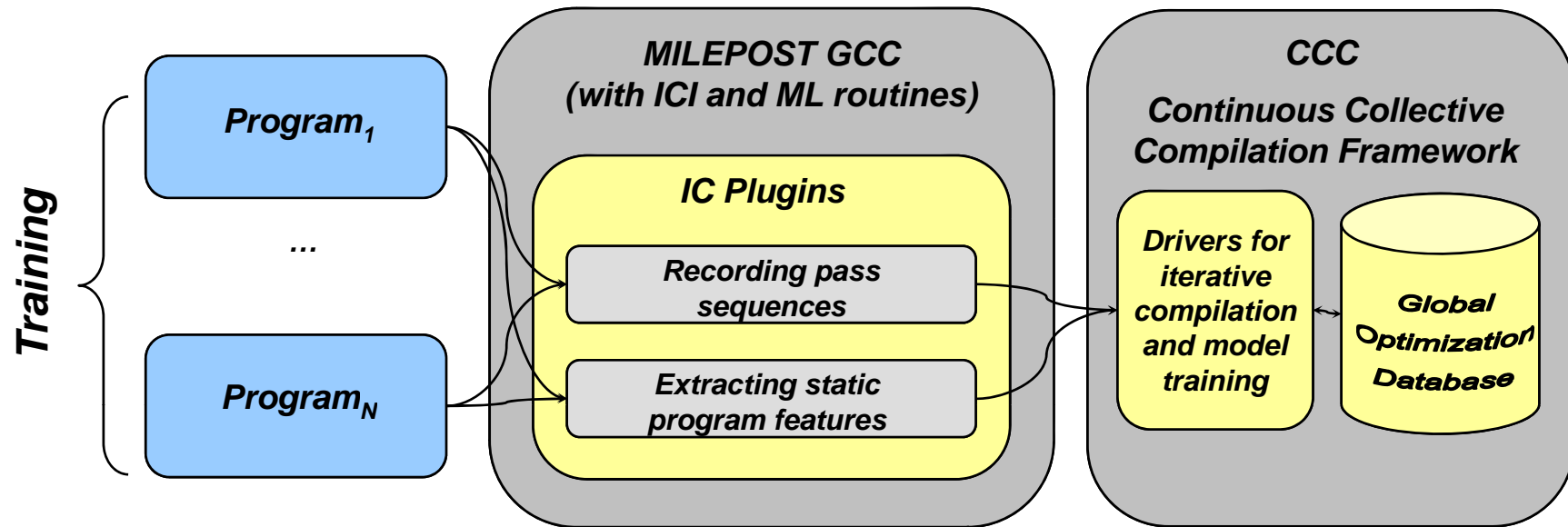

MILEPOST framework

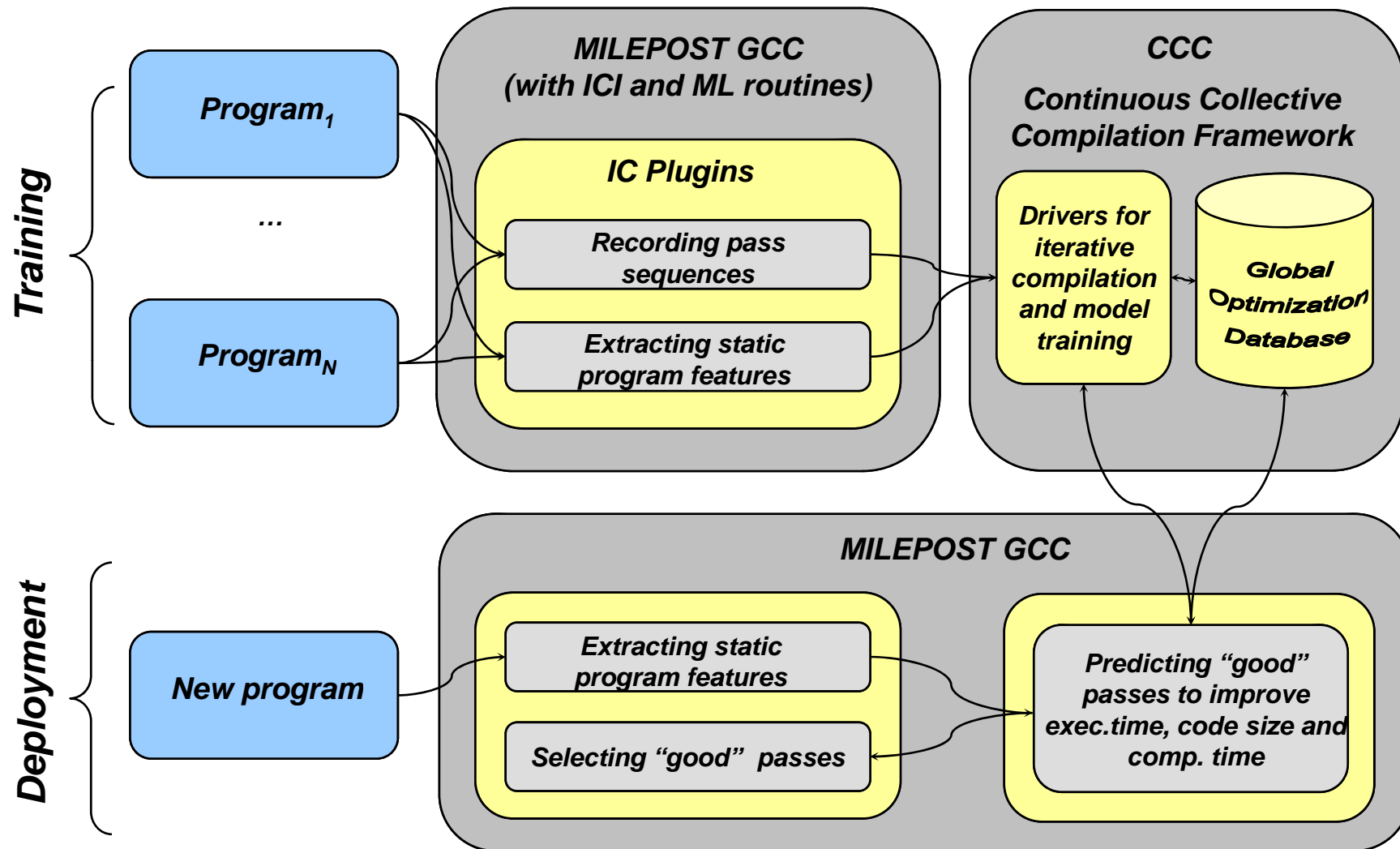

Grigori Fursin, Cupertino Miranda, Olivier Temam, Mircea Namolaru, Elad Yom-Tov, Ayal Zaks, Bilha Mendelson, Phil Barnard, Elton Ashton, Eric Courtois, Francois Bodin, Edwin Bonilla, John Thomson, Hugh Leather, Chris Williams, Michael O'Boyle.

MILEPOST GCC: machine learning based research compiler. Proceedings of the GCC Developers' Summit, Ottawa, Canada, June 2008 (based on CGO'06 and HiPEAC'05 papers)

Interactive Compilation Interface

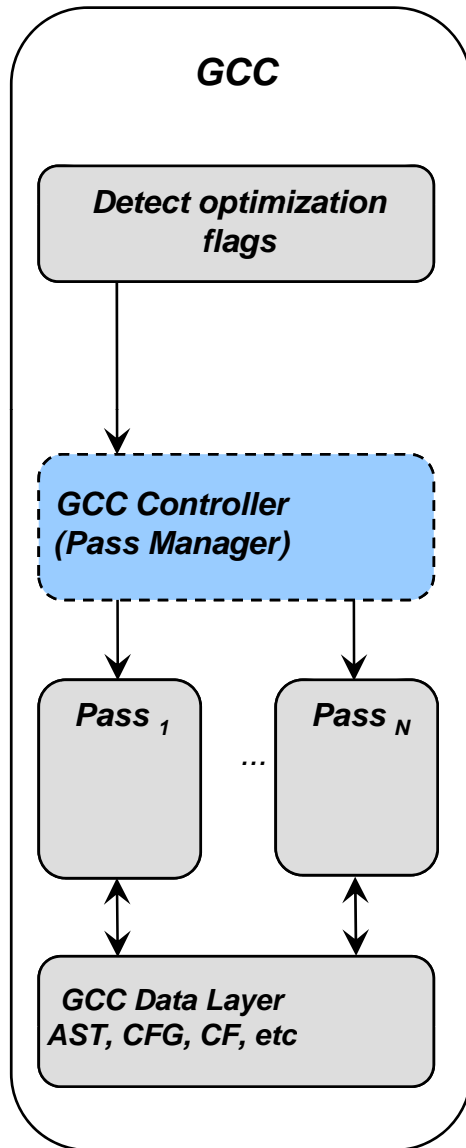

Interactive Compilation Interface

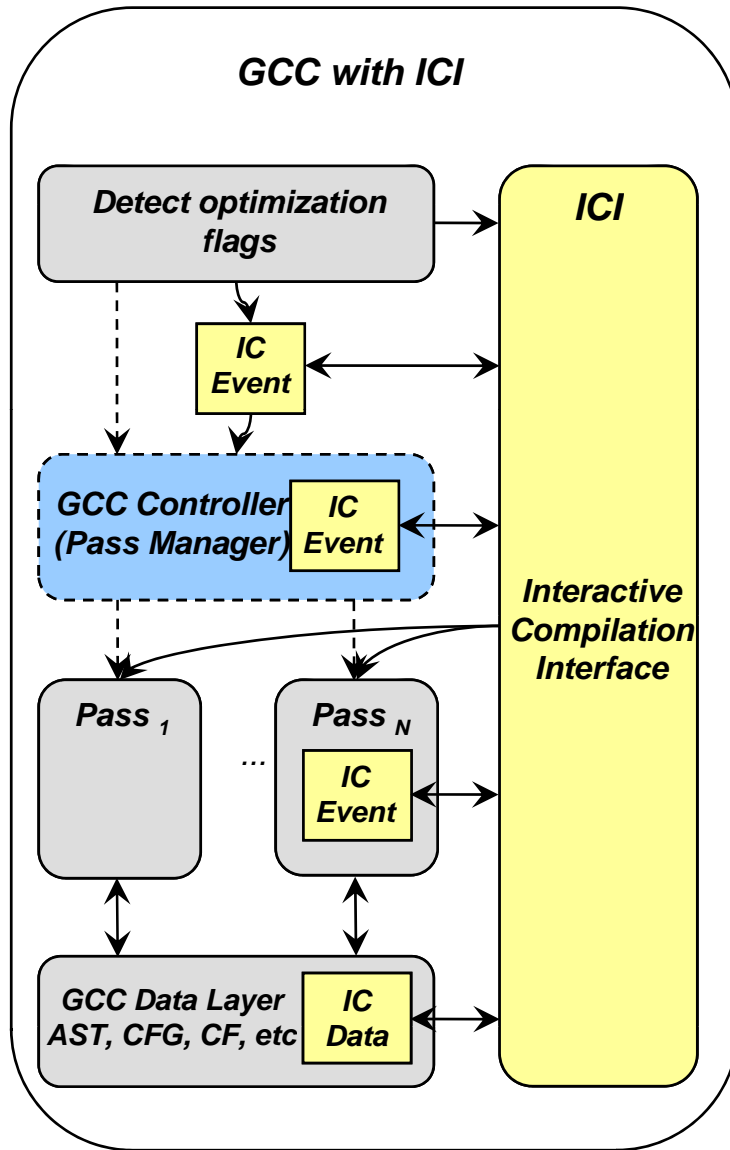

Interactive Compilation Interface

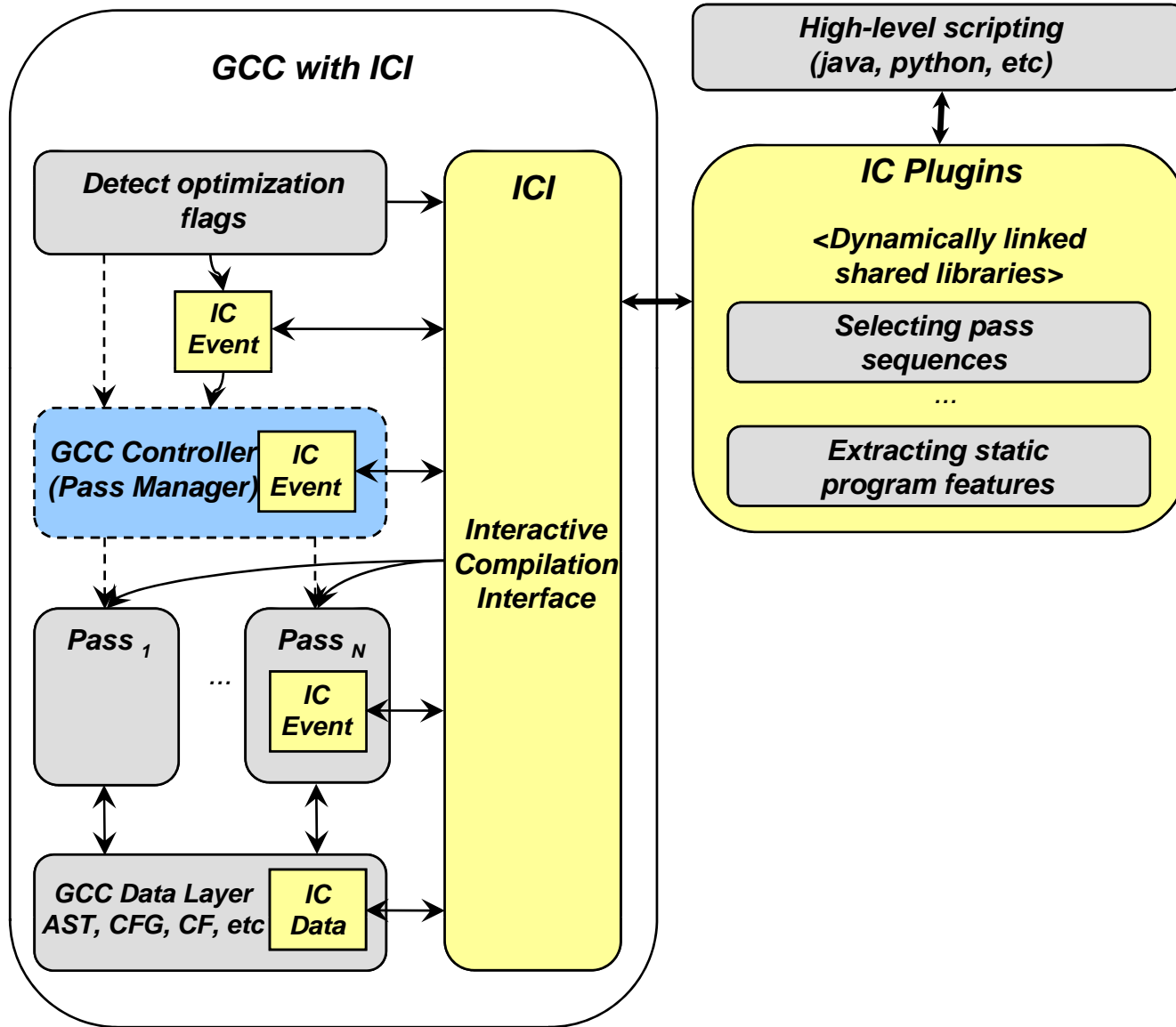

Interactive Compilation Interface

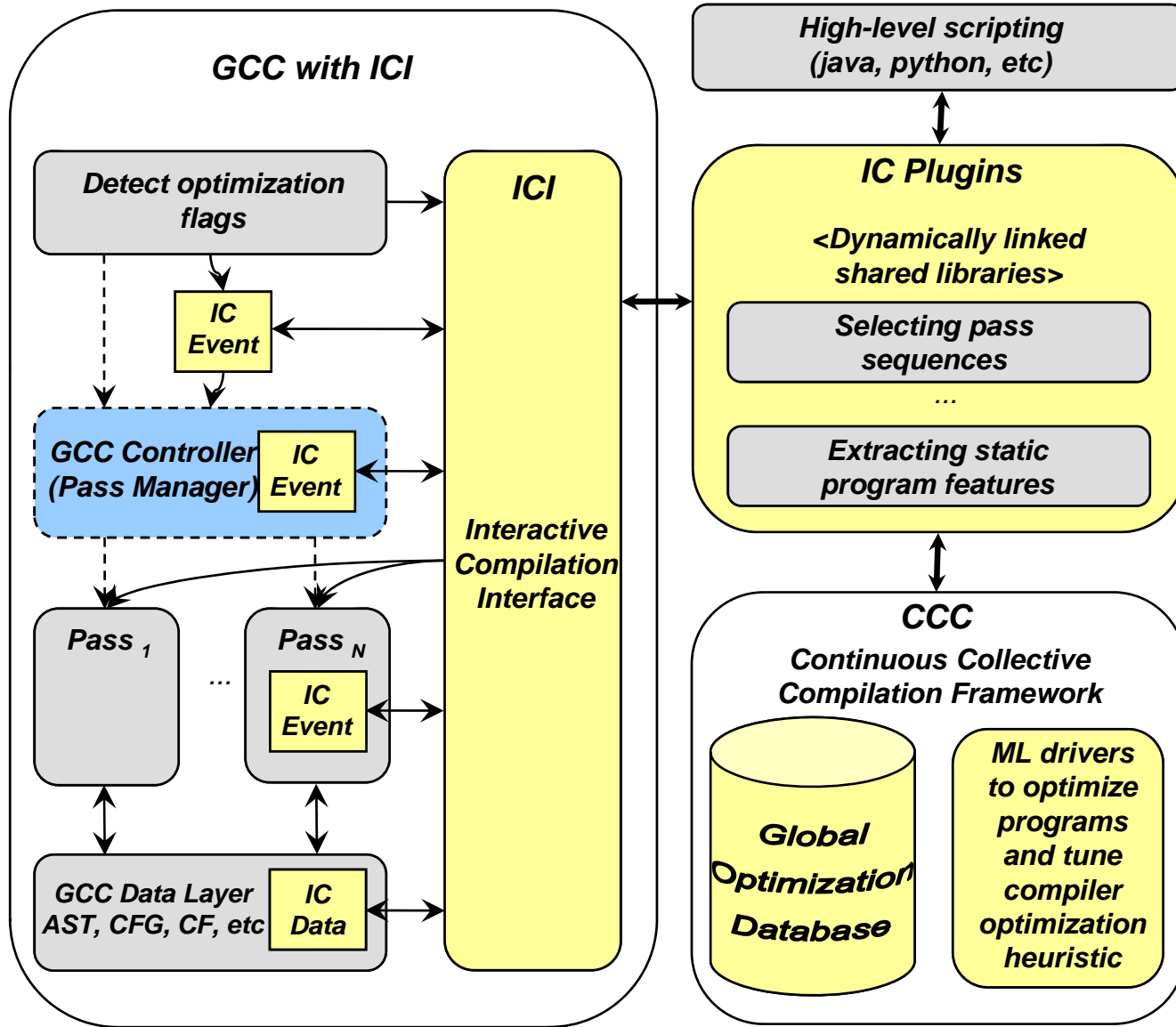

Continuous Collective Compilation Framework

- Framework for collaborative and replicable research on program optimizations (to unify iterative experiments and optimization knowledge reuse)
- Collect and analyze data from various partners in a global database:
- Support iterative compilation (flags & passes) with different strategies, transparent profiling using hardware counters collection using PAPI library
- During last 1 year around 3,000,000 executions on various platforms:
 - **x86, x8664, IA64**
 - **ARC 7xx**
 - **TMS320C6713**
 - **ICT GODSON2**

More information:

- <http://cccpf.sourceforge.net>
- HiPEAC'09 (“Collective Optimization”, Grigori Fursin and Olivier Temam)

New developments

<http://gcc-ici.sourceforge.net>

- port current ICI to GCC 4.4 (with GRAPHITE support)
- support IPA pass selection and reordering
- provide dependencies between passes
- provide global/fine-grain cost model tuning (individual transformations)
- provide fine-grain static feature extraction for machine learning
- provide ability for code instrumentation (adding external function calls, external libraries, adding data arrays for split-compilation, etc)
- port to GCC4NET
- change machine description through ICI
- test suite / documentation

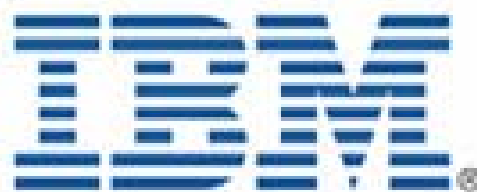

Static multiversioning framework for dynamic optimizations

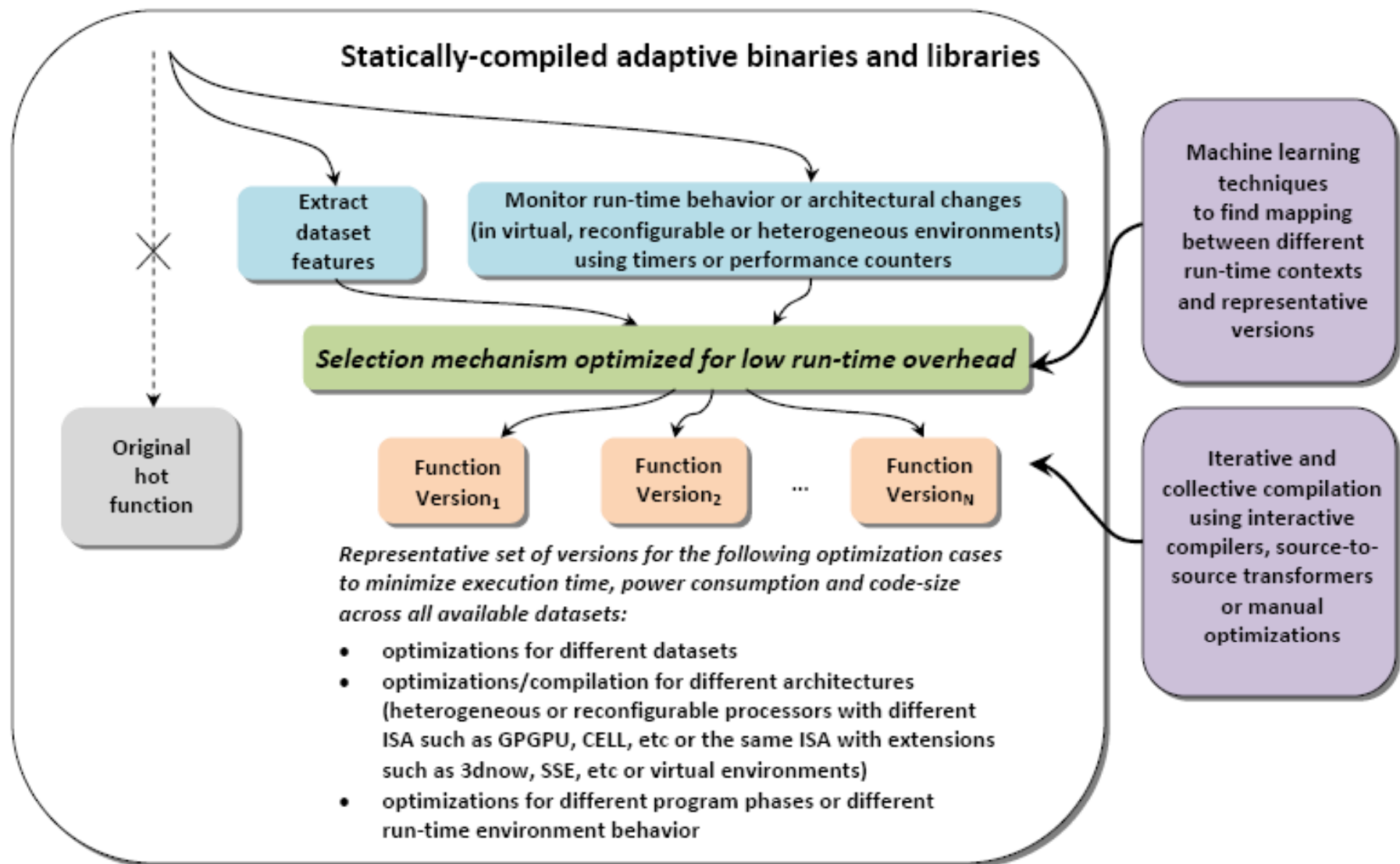

Static multiversioning framework extensions

Add function cloning support to new ICI

Add code instrumentation to new ICI

Evaluate on

- heterogeneous architectures
- reconfigurable architectures
- virtual environments

Thanks

Feedback, support, collaboration ?!

Most tools are or will be available online:

Contact: grigori.fursin@inria.fr

<http://fursin.net/research>

SMART'09 & GROW'09 workshops co-located with HiPEAC'09