

Opening the platform

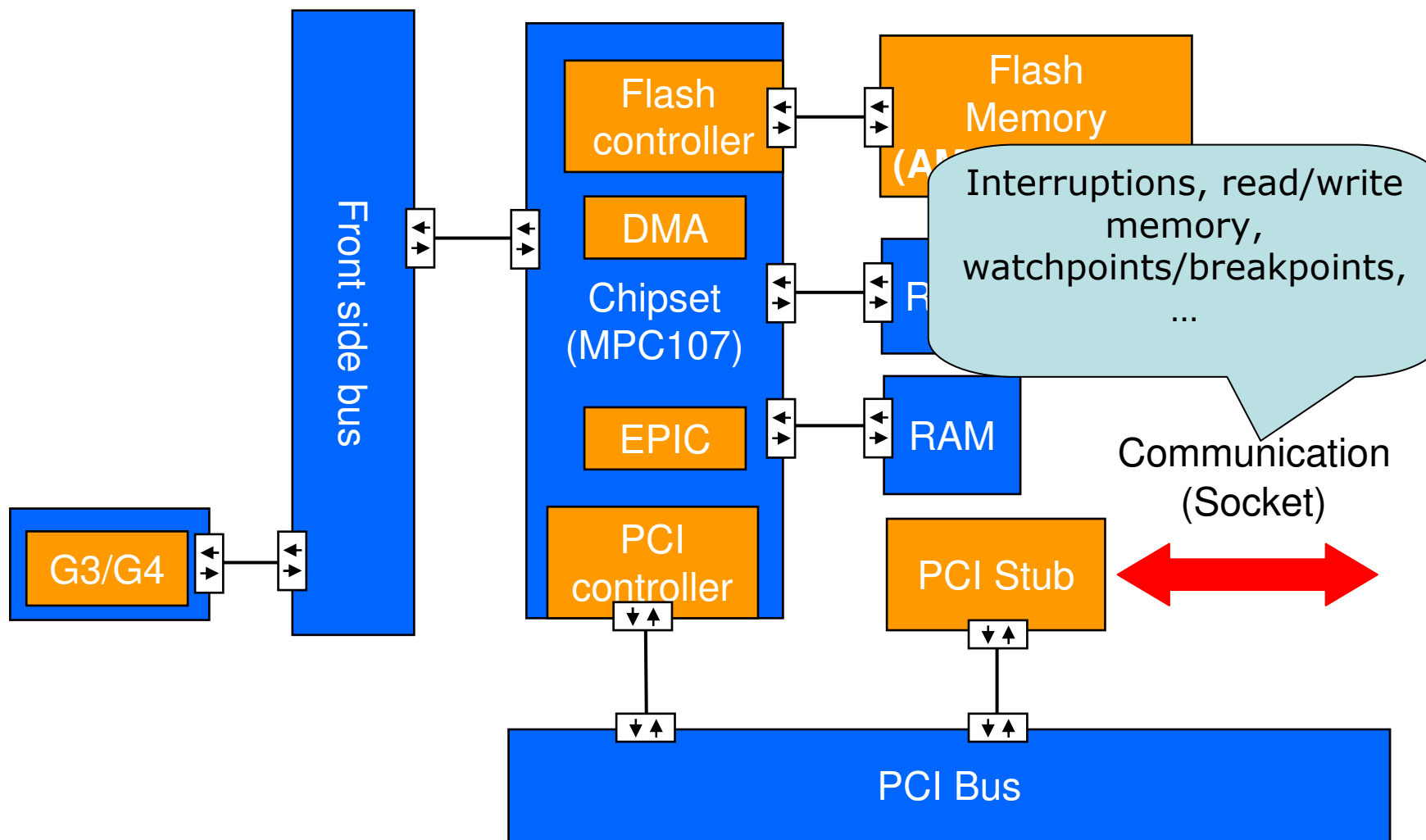

Industrial platform integration

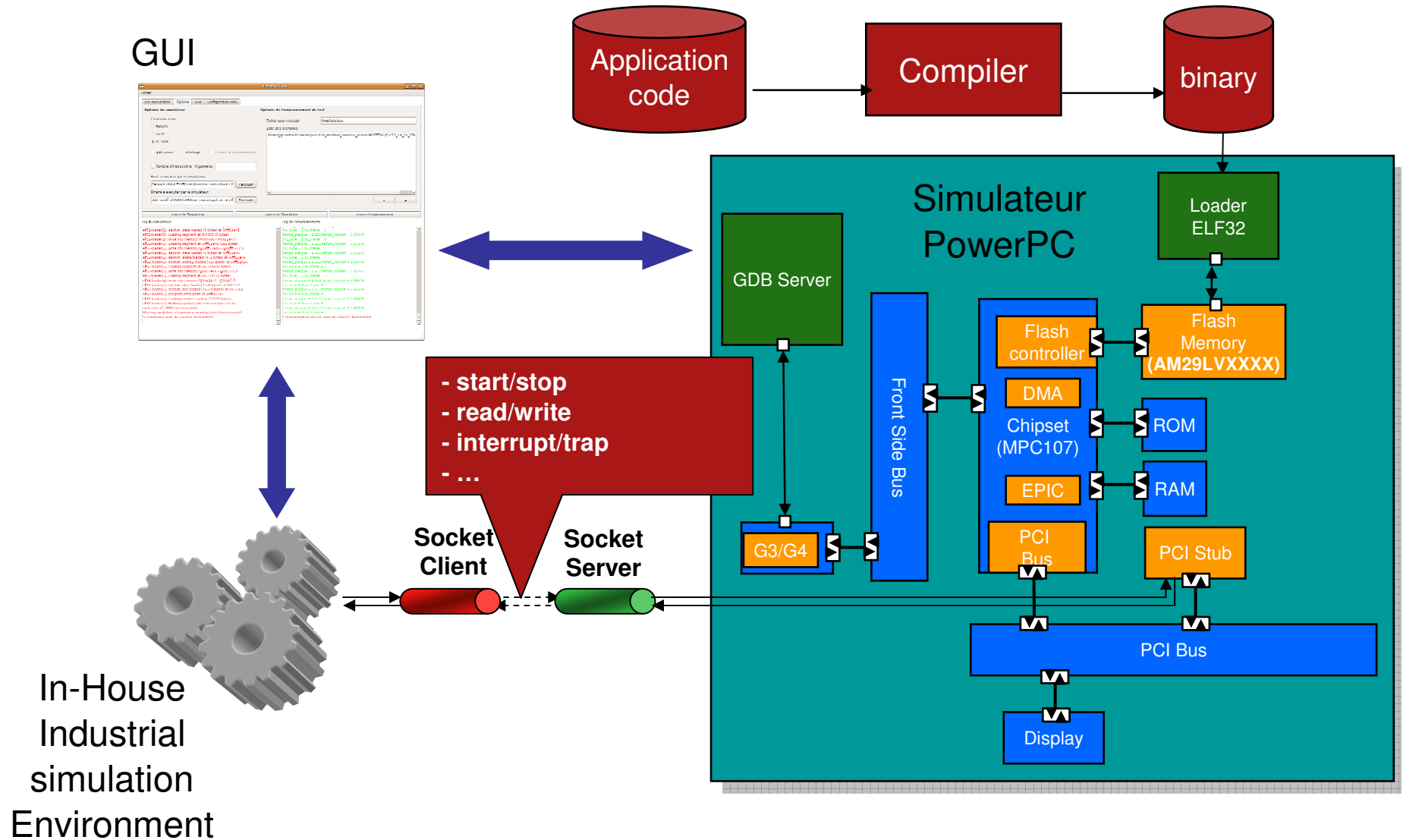

Target architecture

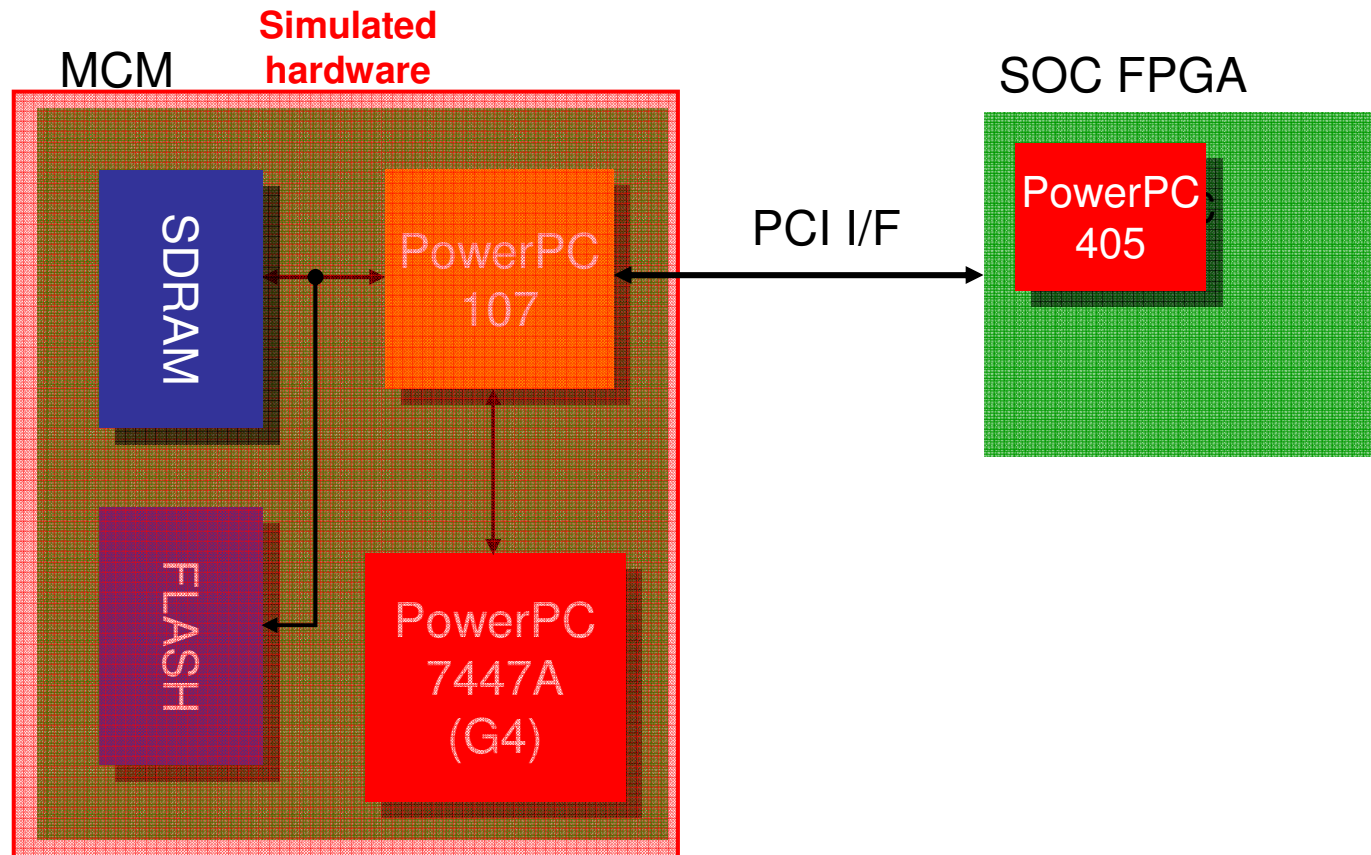

UNISIM SystemC TLM/TTLM available components

➤ Processors :

- ✓ PowerPC 750/7447A/G3/G4
- ✓ ARM7TDMI, ARM966

➤ Processors under development:

- ✓ ARM9TDMI
- ✓ Star12X

➤ Peripherals under development:

- ✓ Ethernet controller
- ✓ Serial port Intel 16550
- ✓ Keyboard controller Intel 8042
- ✓ AMBA bus (ARM)
- ✓ AMBA-PCI bridge (ARM)

➤ Available peripherals:

- ✓ System snooping bus
- ✓ PCI bus
- ✓ PCI – ISA bridge
- ✓ MPC107 chipset (host-to-PCI bridge) :
 - ✓ PCI controller
 - ✓ DMA
 - ✓ EPIC
- ✓ Video: Frame-buffer connected to the PCI bus
- ✓ Hard drive: IDE controller with DMA connected to the PCI bus
- ✓ Programmable interrupt controller (Heathrow. EPIC)
- ✓ Flash memory (AMD AM29LVXXXX)
- ✓ PCI stub